

DWG NO.

NO.	NOMENCLATURE	MATERIAL	Q'TY	TREAT	REMARKS

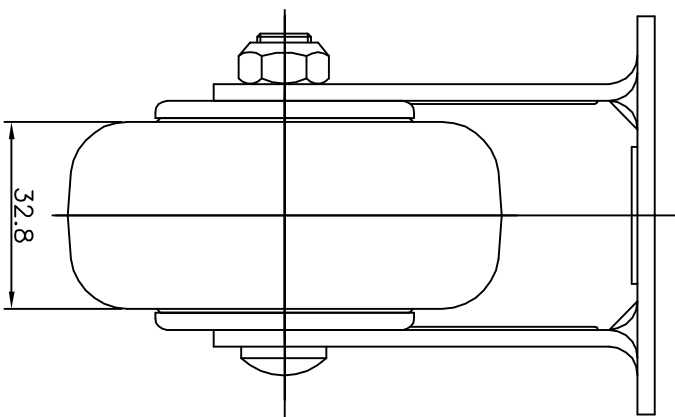
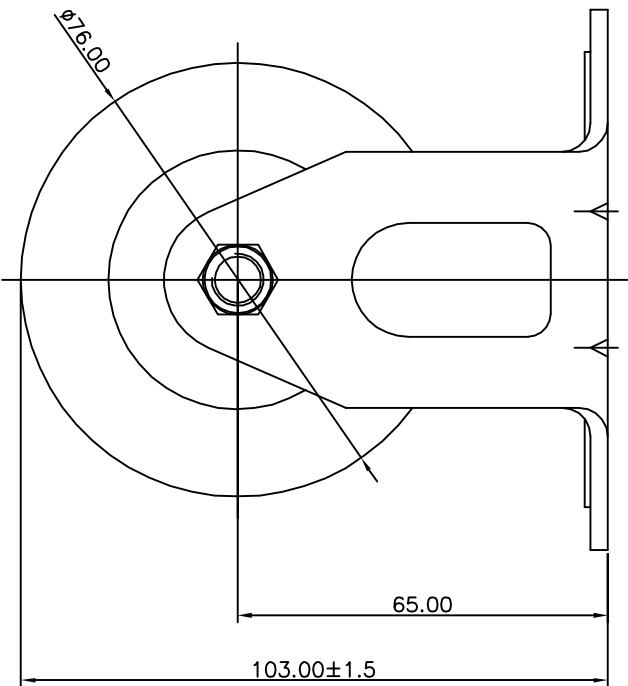
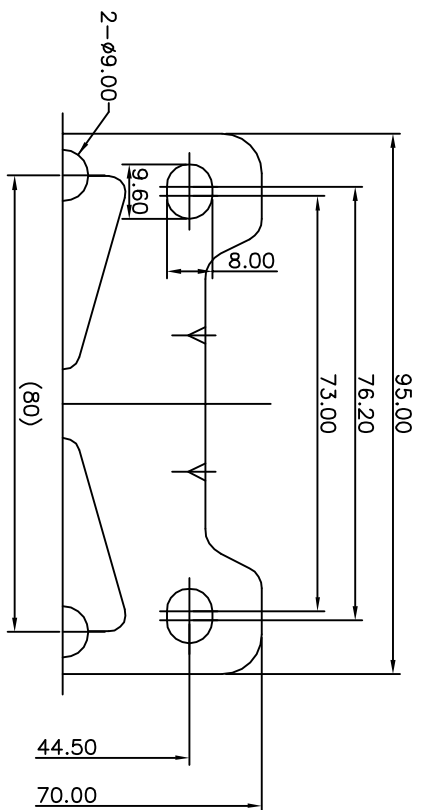

THIRD ANGLE DRAW	SCALE	DATE	MEMO	DATE	SIGN	NAME	TP5030R-04-PLY-TG-RED ASS'Y
△	1 / 1	2015.07.03					
△						DRAWN	DESIGN
△						CHECKED	APPROVED
△							

SAM SONG MFG. CO., LTD. REF. NO.